

Amber 400

MEFA Amber has been designed as a typical Danish mailbox of a high quality and with soft lines and many attractive little details.

The mail compartment is particularly large and holds substantial quantities of mail.

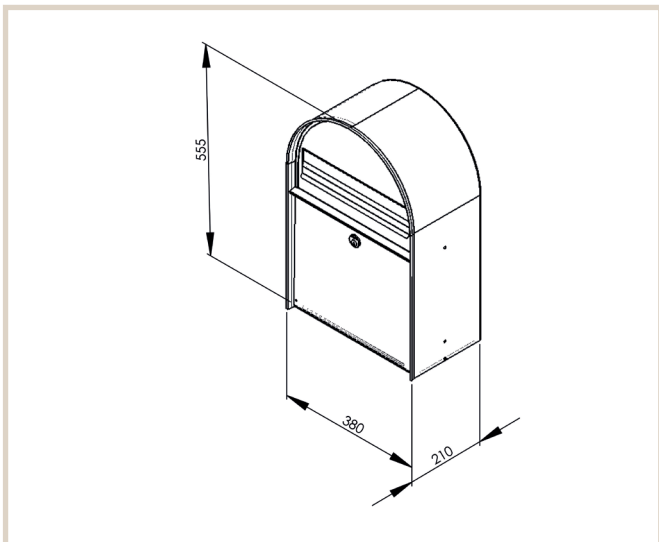

Technical info:

Height: 555 mm

Width: 380 mm

Depth: 210 mm

Lock:

MEFA security lock

Art. no.:

Galvanised: 400900M

Traffic white: 400000M

Jet black: 400100M

Antracite grey: 400500M

Stainless steel: 400020M



Korskildeeng 6 - DK - 2670 Greve

E-mail: info@renzgroup.dk

Tel: +45 4619 3500

www.me-fa.com